

4
NEXT ASSEMBLY
-

3
2
1

REVISION	ZONE	DESCRIPTION	DATE	DRWN	APVD
SHT2 SHT1	-	DRR-1479	FEB 5, 07	JM	SR
-	A	DRR-1516	FEB 22, 07	SR	
-	B	DRR-1529	MAR15, 07	JM	

WIRES CONNECTED TO CONTROL PANEL: 2, 3C, 35

SHIELDED: X1, X2, X3 (WITH REMOTE POT ONLY)

WIRES GOING INTO VFD MUST BE SHIELDED AND ONE END GROUNDED

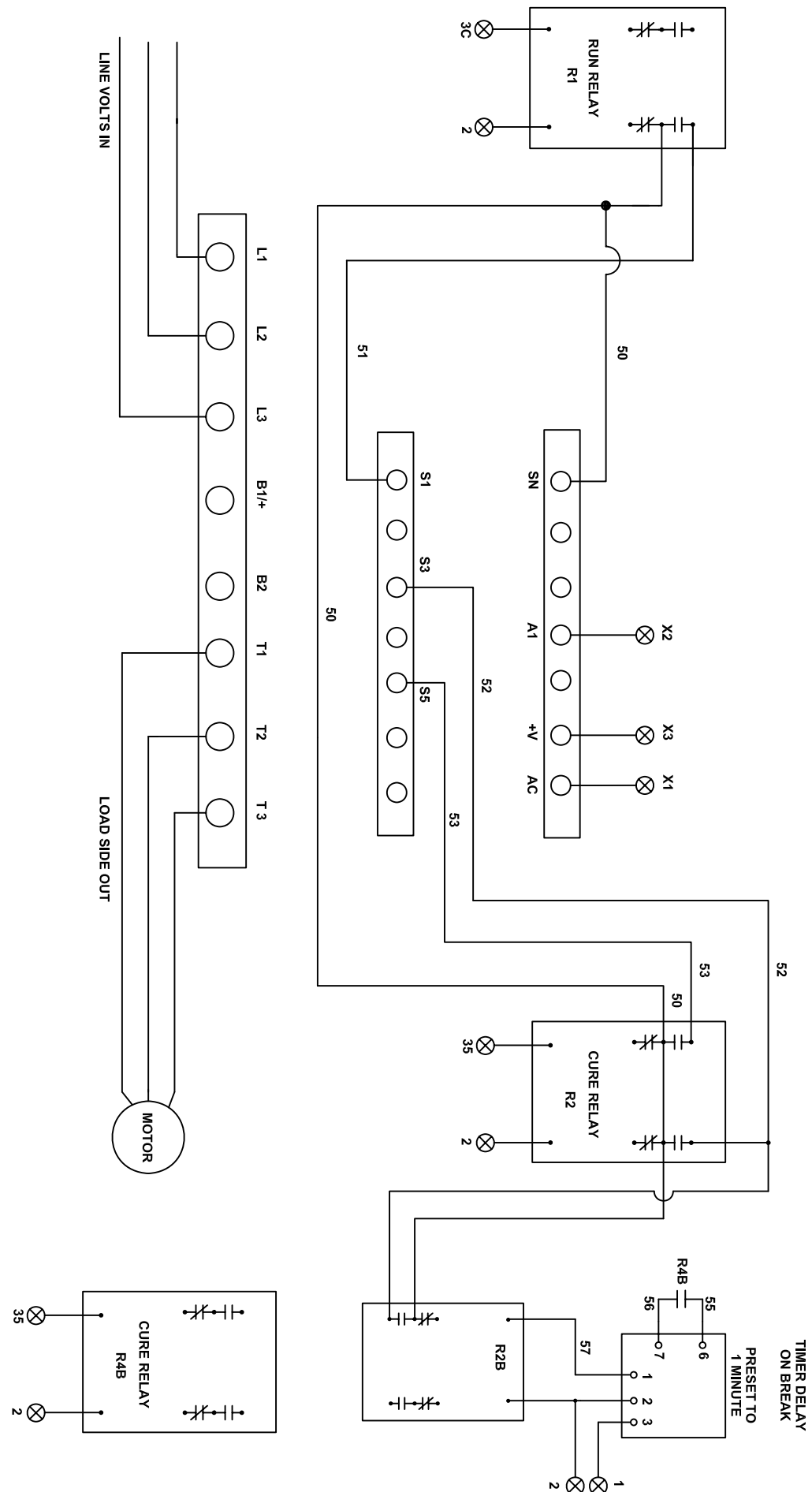

PROGRAM PARAMETERS

A1-03=2220, C1-01=7 SEC, C1-02=10 SEC, C1-03=10 SEC, C1-04=150 SEC
 D1-02=38Hz, H1-01=7, H3-09=1F

DATE: FEB. 5, 07	DESIGNED BY: J. MCGO	SCALE: NONE	DWG. TYPE: ENG	LOCATION: B/FLO	SHEET: 1 OF 1
TOLERANCES AS NOTED	UNLESS OTHERWISE SPECIFIED	TITLE: YASKAWA P7 1 POT VFD	SIZE: C	DRAWING NUMBER: 06191	REV.: B
3 DECIMAL PLACES ±.02	APPROVED BY/DATE:				
ANGLES ±1°					
FINISH: -					